

Part No. 8095

LASER[®]

HP Diesel Fuel Pump Removal Tool - for Mercedes-Benz 1.6/2.0 Instructions



www.lasertools.co.uk

Introduction

The Mercedes-Benz W654 1.6 and 2.0 diesel engines use a timing chain driven high pressure diesel fuel pump. The timing chain is mounted at the back of the engine which means any task involving its removal will require the engine to be removed unless the pump sprocket can be held in place while the pump is extracted. The Laser 8095 allows the user to lock the pump sprocket securely in place while removing and refitting the HP fuel pump without disturbing the drive chain.

- Equivalent to OEM W654 589 0014 00
- Designed to be used with the engine in the vehicle.

Make, Model, Year		Engine Code
Mercedes-Benz	A Class	from 2019
	B Class	from 2019
	C Class	from 2018
	CLA	from 2019
	CLS	from 2018
	E Class	from 2016
	GLB	from 2019
	GLC Coupe	from 2019
	GLE	from 2019
	V Class	from 2019
	Vito	from 2019

The following instructions are for guidance only. Please refer to OEM derived data such as the vehicles manufacturers own data or Autodata.

The use of this tool is purely down to the user's discretion and The Tool Connection Ltd. cannot be held responsible for any damage caused what so ever.

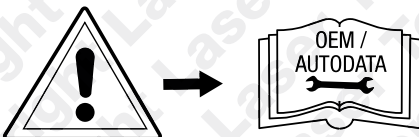

Components

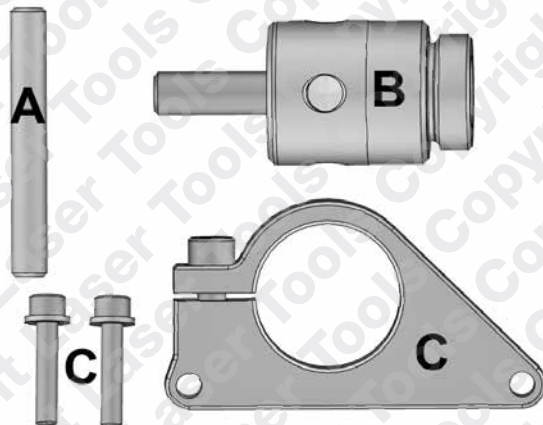

Ref.	Description	OEM No.
A	Push Rod	W654 589 0014 00
B	Holding Tool & Threaded Force Screw	
C	Mounting Bracket	

Instructions

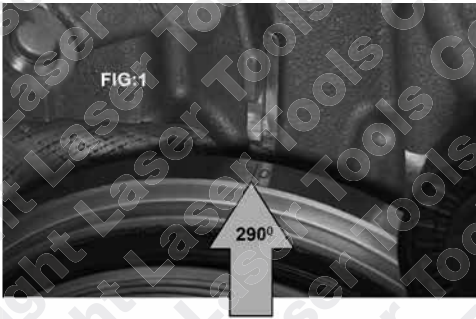

- Always refer to manufacturer specific data and instructions
- The HP fuel pump is located at the rear of the engine.
- Align the 290 degree mark on the crankshaft pulley as shown in **figure 1**.

- Remove the high and lower pressure fuel pipes from the pump.
- Remove the fuel pump holding bracket (**do not** remove the 2 fuel pump main fixing bolts.)
- Remove the glow plug output control box.
- Remove the rubberised cap from the fuel pump sprocket access hole on the back of the engine block by punching a hole and levering the cap out. The cap must be replaced. **See figure 2.**

NOTE: Engine and transmission shown removed for clarity only.

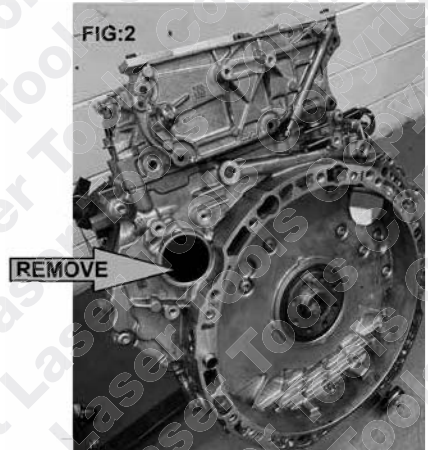

- While holding the crankshaft pulley with a suitable pulley holding tool undo and remove the HP fuel pump sprocket holding bolt as shown in **figure 3**.

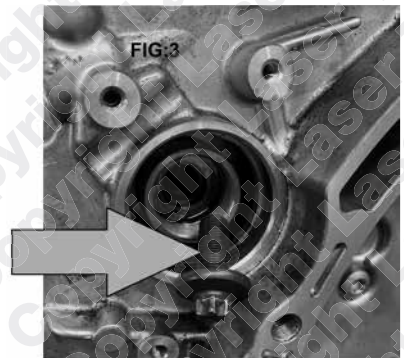

Instructions

FIG:4

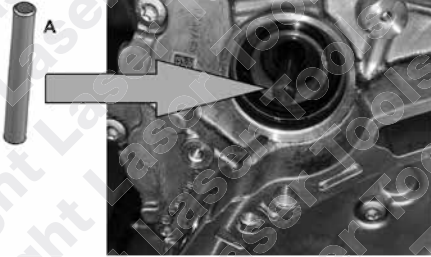

Component A: - Push Rod

- Fit component **A** as shown in **figure 4**.

Components B: - Holding Tool & Threaded Force Screw

- Before fitting unscrew the central force screw and then screw the holding tool into the large thread of the pump sprocket as shown in **figure 5**. Hand tighten only.
- For removal only: if required use a suitable round bar or screwdriver in the holes marked (a).

FIG:5

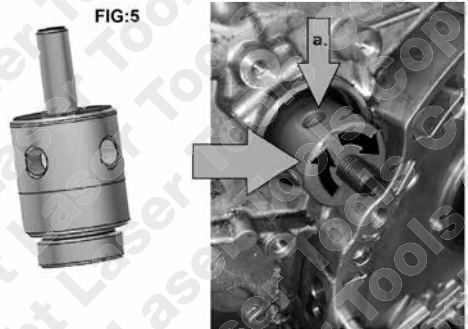

Component C:- Mounting Bracket.

- Fit the mounting bracket as shown in **figure 6** and tighten the 2 fixing bolts (b) to the engine block and then tighten the clamp bolt (c).

FIG:6

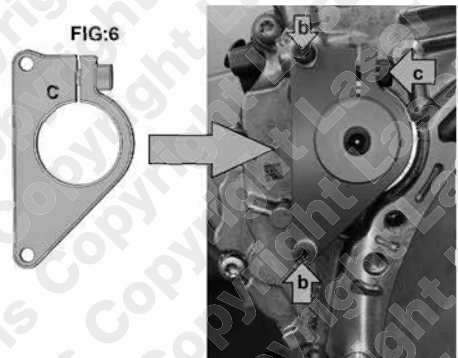

Instructions

- **BEFORE** tightening the force screw remove the 2 fuel pump holding bolts as shown in **figure 7a & b**.

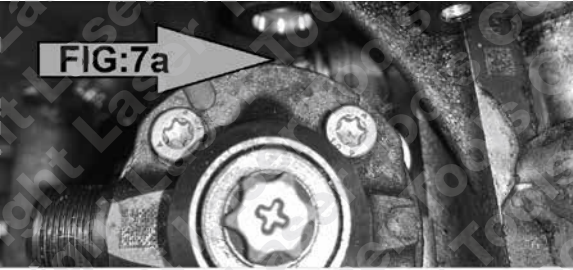

HP Fuel Pump Removal:

- With the pump mounting bolts, feed pipes and return pipes removed finally turn the force screw clockwise to push the pump out of the sprocket as shown in **figure 8a & b**.

WARNING: While the pump is removed **DO NOT** attempt to remove the tool from the engine block.

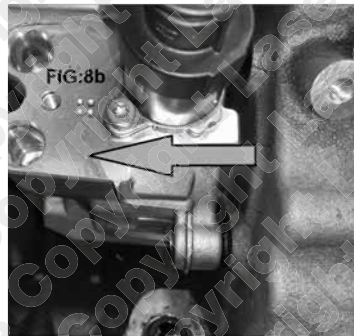

- Reverse the above procedure to re-fit the pump, making sure the dowel in the sprocket is correctly aligned with the slot in the fuel pump shaft.

N.B. Observe manufacturers tightening sequence and torques for fixing and bolts.



Safety First. Be Protected.

Our products are designed to be used correctly and with care for the purpose for which they are intended. No liability is accepted by the Tool Connection for incorrect use of any of our products, and the Tool Connection cannot be held responsible for any damage to personnel, property or equipment when using the tools. Incorrect use will also invalidate the warranty.

If applicable, the applications database and any instructional information provided has been designed to offer general guidance for a particular tool's use and while all attention is given to the accuracy of the data no project should be attempted without referring first to the manufacturer's technical documentation (workshop or instruction manual) or the use of a recognised authority such as Autodata.

It is our policy to continually improve our products and thus we reserve the right to alter specifications and components without prior notice. It is the responsibility of the user to ensure the suitability of the tools and information prior to their use.

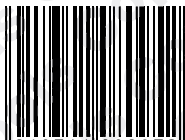

When you have finished with this product please recycle it

www.lasertools.co.uk

8095_Instructions

Guarantee



Distributed by The Tool Connection Ltd
Kineton Road, Southam, Warwickshire CV47 0DR
T +44 (0) 1926 815000 F +44 (0) 1926 815888
info@toolconnection.co.uk www.toolconnection.co.uk

If this product fails through faulty materials or workmanship, contact our service department direct on: **+44 (0) 1926 818186**. Normal wear and tear are excluded as are consumable items and abuse.

www.lasertools.co.uk